

Cordless Cellular Fabric Shade

OWNER'S HANDBOOK

NO TOOLS REQUIRED FOR INSTALLATION

PLEASE READ THESE INSTRUCTIONS CAREFULLY & THOROUGHLY TO ASSURE A SUCCESSFUL INSTALLATION!

INSTALLATION INSTRUCTIONS

Step 1. Check Package Contents

Missing part? Call 1-800-264-1190

Mounting hardware kit includes the following:

Part	Quantity
a. Mounting Brackets	2 (for 18" to 36" wide shades) 3 (for 36 1/8" to 48" wide shades) 4 (for 48 1/8" to 72" wide shades)
b. Handle for Bottom Rail	1 2 (for shades over 59" wide)
c. Optional Hold-Down Brackets	2
Adhesive pads for Hold-Downs	2

Step 2. Bracket Location, Alignment and Installation

Brackets & Mounting Tape:

Each bracket is attached to an installation plate. Each Installation Plate has two sections of state-of-the-art 3M mounting tape attached to it. This is a powerful, permanent adhesive – care is required to apply it properly. **DO NOT REMOVE THE COVERS FROM THE ADHESIVE STRIPS UNTIL ALL ALIGNMENT AND SURFACE PREPARATION STEPS HAVE BEEN COMPLETED.**

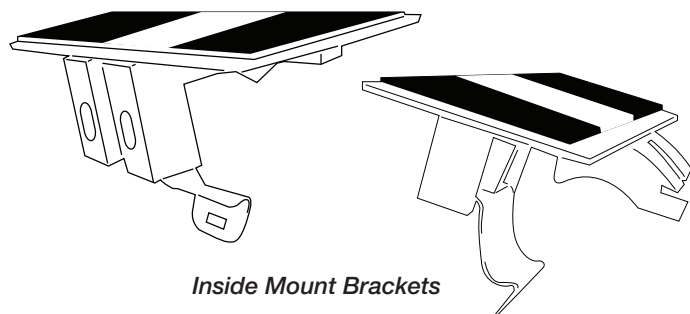
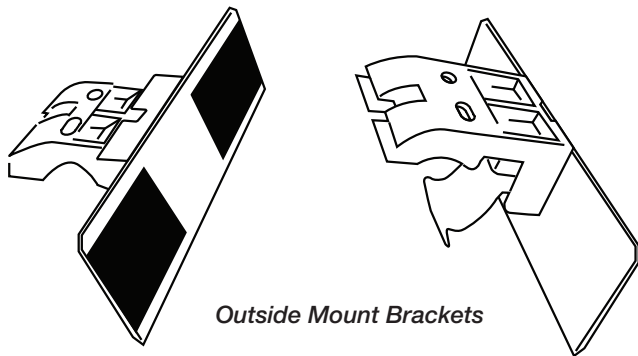

A mounting bracket should be positioned about 1" to 6" from each end of the head rail. For wider shades that require 3 or more brackets, these should be spaced evenly between the two outermost brackets.

The procedure outlined below will assure proper bracket placement.

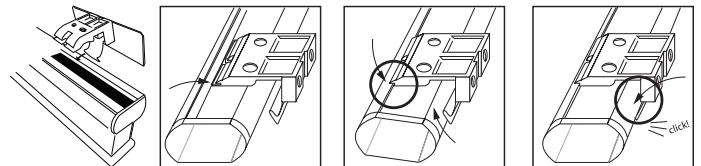

Attach the brackets to the head rail as illustrated, positioned as described above. The inner front edge of the head rail slides into the slot at the front of each bracket. Push the brackets downward until the flexible tab at the bottom of each bracket snaps onto the back of the head rail.

Your shade may be installed either inside the window frame or outside the window frame.

Inside Mount

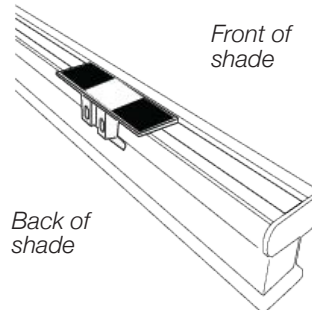

Outside Mount

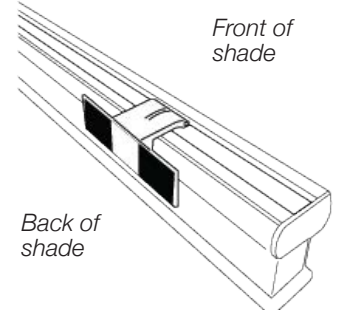

Surface Preparation

The surface that the brackets will be attached to must be clean, dry and flat. Alcohol pads are included to simplify this process. Lightly rub the alcohol where the brackets will be attached, and then fan these spots with a magazine or piece of paper – the alcohol will dry quickly.

Alignment & Attachment – Inside Mount

Hold the shade with the brackets attached in place in the window opening and make a pencil mark at the rear of each bracket plate where it contacts the inside of the window frame.

Remove the brackets from the head rail. Now, one bracket at a time, peel off the thin red layer that covers each adhesive mounting pad. Align each bracket with one of the pencil marks – **DO THIS SLOWLY AND PRECISELY – WHEN THE ADHESIVE TOUCHES THE MOUNTING SURFACE IT CANNOT BE REMOVED WITHOUT DESTROYING THE BRACKET ASSEMBLY.**

Press each bracket firmly in place for at least 30 seconds. If practical, wait at least an hour before attaching the shade to the brackets. For the first 24 hours try to operate the shade as infrequently as possible.

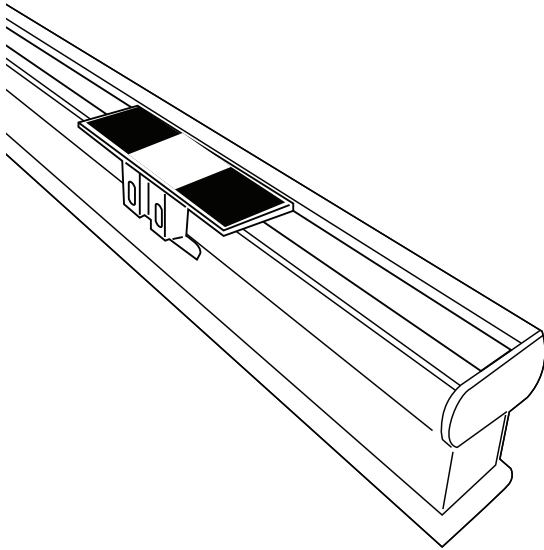

Alignment & Attachment – Outside Mount

Hold the shade with the brackets attached at the height desired on the wall or window frame, and center it over the window opening. Mark the exact location of each bracket with a pencil.

Remove the brackets from the head rail. Now, one bracket at a time, peel off the thin red layer that covers each adhesive mounting pad. Align each bracket with one of the pencil marks – **DO THIS SLOWLY AND PRECISELY – WHEN THE ADHESIVE TOUCHES THE MOUNTING SURFACE IT CANNOT BE REMOVED WITHOUT DESTROYING THE BRACKET ASSEMBLY.**

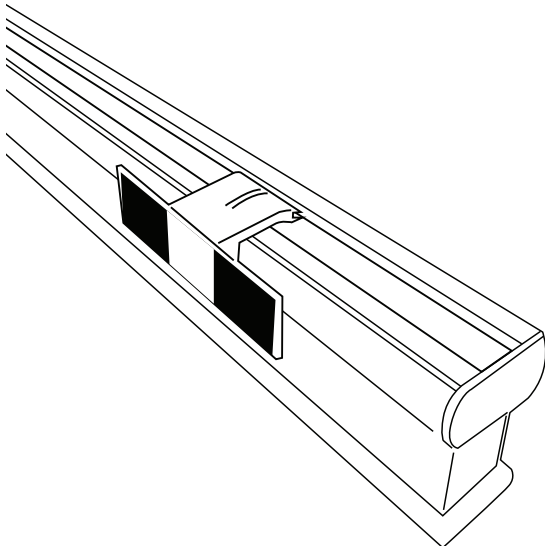

Press each bracket firmly in place for at least 30 seconds. If practical, wait at least an hour before attaching the shade to the brackets. For the first 24 hours try to operate the shade as infrequently as possible.

Step 3. Attach Handle(s)

Attach the Handle to the bottom rail as illustrated. The handle is designed to minimize contact with the shade fabric. Always raise and lower the shade **SLOWLY(!)** to assure that

the pleated fabric stacks neatly.

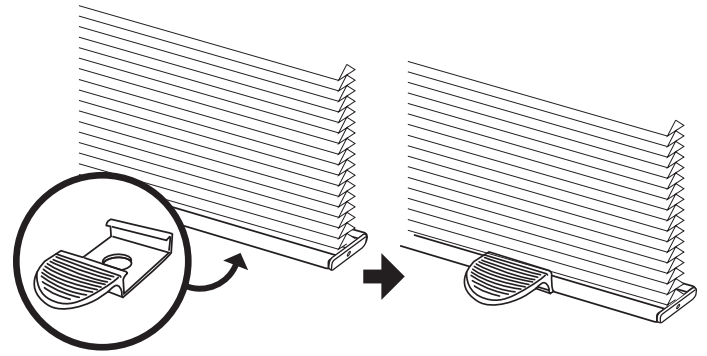

Wider shades have (2) Handles – to precisely determine the correct position for each handle, divide the total width of the shade by 4, and then attach one handle that distance from each outside edge of the shade – always grasp both handles when lifting and lowering the shade.

Step 4. How to Operate

IMPORTANT
Operating & Care Instructions for Cell Shades
READ CAREFULLY

- Make sure that the Handles have been attached to the rail(s) as described above (see Step 4)
- To maintain optimal performance of the springs that make your cordless shade function, lift and lower your shade through its full range of motion – all the way up and down – every day if possible.
- For shades with a single handle, which must be centered on the rail(s), lift or lower the shade slowly and evenly, keeping the rail(s) level, until the shade is positioned as desired.
- For wider shades with a double set of handles, grasp the handles using both hands and lift the shade slowly and evenly, being sure to keep the rail(s) level.
- If you have trouble lifting your cordless shade:
- If the shade is left in one position for a long period of time, it might be necessary to lift and lower the shade several times to restore normal function. If the shade has been fully raised for a long period of time, it might tend to spring-back (rebound) slightly from the desired length position. This can also be remedied by lifting and lowering the shade several times.

Always raise and lower the shade **SLOWLY(!)** to assure that the pleated fabric stacks neatly. To lower the shade: grip the bottom rail handle and slowly pull straight down. To raise the shade, grip the bottom rail handle and push up slowly. Always keep the bottom rail level.

Installation of Optional Hold-Down Brackets

Hold down brackets are provided for optional use. These brackets should be used only if the shade is to be in a

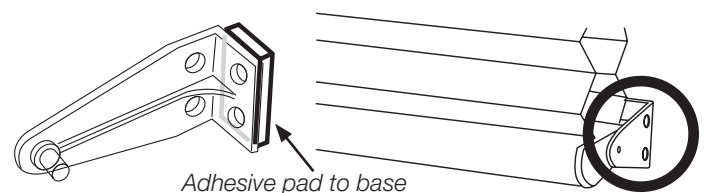

permanently lowered position. With the shade fully lowered, make pencil marks at the outside ends of the bottom rail. Remove the liner from one side of each adhesive pad and attach it to the base of each bracket as illustrated. Brackets should then be lined up to the pencil marks and attached by removing the liner from the other side of the adhesive tape.

Removal of Brackets

This product is meant for permanent applications but it can be removed. Because this is a permanent adhesive, damage to the mounting surface the object is mounted to is a distinct possibility in the removal process. Expect that some patching and refinishing of the surface will be required.

To remove the brackets, insert a knife above each mounting plate and cut the foam tape between adhesive surfaces using a sawing motion. A thin wire, or dental floss can also be used to cut the tape. Hold one end of the wire or floss in each hand; bring the wire or floss between the mounted surfaces and using a sawing motion cut the tape in half. Remove the remaining material from the surface with your fingers or scrape it with a putty knife. The use of citrus solvents may soften the adhesive to aid removal. Do not expect citrus solvent or other solvents to dissolve the adhesive as acrylic adhesives do not dissolve in solvents.

CLEANING

The vinyl head rail and bottom rail can be wiped clean with a damp sponge. To clean the shade fabric, use a feather duster or vacuum lightly using the soft brush attachment.

REPLACEMENT PARTS

In the event that replacement parts are ever needed, Please be sure to provide the following information, if possible:

- The complete model or catalog number of your product
- A description of the product
- A description of the part needed

LIMITED LIFETIME WARRANTY

The enclosed product is warranted to the original residential retail purchaser as long as the product remains in the original window.

Covered:

Lifetime: Entire product against manufacturing defects (i.e. a flaw in the product design, materials, or workmanship that causes the product to no longer function)

5 years: All fabric

Not Covered:

Normal Wear and Tear

Any product that fails due to: • abuse • exposure to salt air • improper installation • accident • extraordinary use

• improper operation • alterations • improper cleaning • misapplication • damage from pests/insects/pets • improper handling • misuse

Costs associated with: • product removal • transportation to and from the retailer • brand label removal • product re-measure • incidental or consequential damages • product reinstallation •

shipping

In the event there are multiple blinds/shades in the same room, only the defective blind/shade will be replaced.

To Report Shipping Damage: If damage occurred during shipping, call place of purchase and report within 7 calendar days or else you may be denied credit for your damaged product.

To Obtain Service: If you suspect this product has a manufacturing defect in materials or workmanship: 1. Locate the sales receipt 2. Call place of purchase. Any unauthorized returns will not be accepted.

Warranty Remedy: THIS SHALL BE YOUR SOLE REMEDY UNDER THIS LIMITED WARRANTY.

If this product is found to have a manufacturing defect in materials or workmanship, we will (at our discretion) do one of the following:

• repair the product • replace the product • refund the cost of the product

Colors vary from lot to lot and may not exactly match sample swatch or previous purchases.

Discontinued items or color selections will be replaced with the closest equivalent current product.

YOUR RIGHTS UNDER STATE LAW:

This lifetime limited warranty gives you specific legal rights, and you may have other rights, which vary from state to state. Some states do not allow limitations on how long a warranty lasts, so the above limitations may not apply to you. No agent, representative, dealer, or unauthorized employee has the authority to increase or alter the obligation of this warranty. This lifetime limited warranty supersedes any previous versions.